

TASK 3.2: Intelligent turbocharging

Objectives:

- Variable flow area turbocharger components for two and four stroke diesel engines
- Investigation of electrically assisted turbocharger (PTI/PTO) for two stroke diesel engines
- Multistage turbocharging investigations

Progress Highlights:

- Variable flow area components simulations (1D, CFD), completed
- Conceptual study of variable compressor area component, in progress
- PTI / PTO test unit design and manufacturing complete
- Special bearing configurations
- Electric or hydraulic actuators studies, in progress

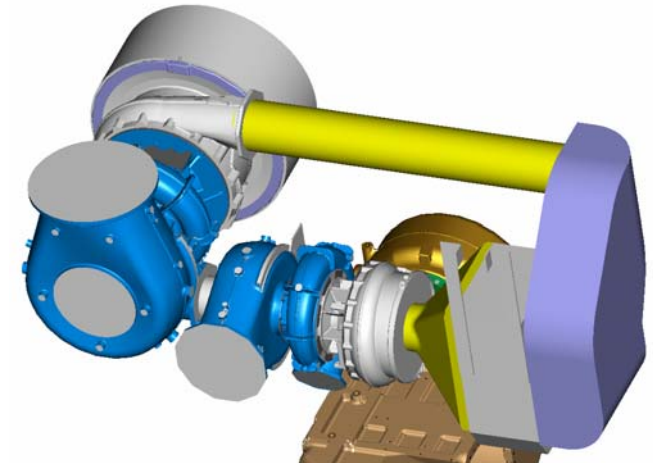
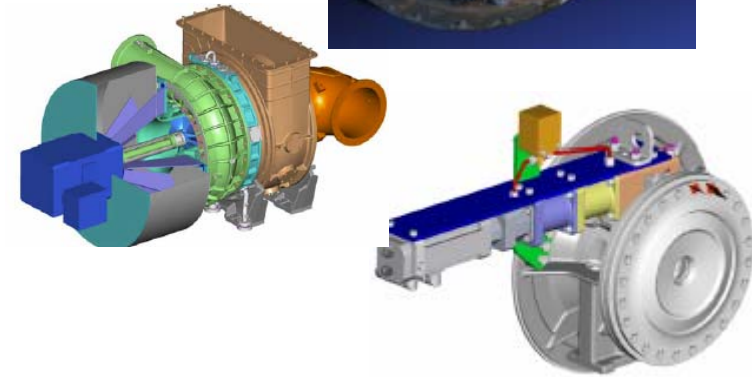

Partners:

