



MAN B&W Diesel

HERCULES Task 7.2: Emission reduction methods (internal – exhaust gas)



Work completed first year:

- Specification and design of EGR system completed
- Definition of measuring methods mostly finalized
- Measurement of reference PM values (actual state-of-the-art) on 7 different engine types



MAN B&W Diesel

HERCULES Task 7.2: Emission reduction methods (internal – exhaust gas)

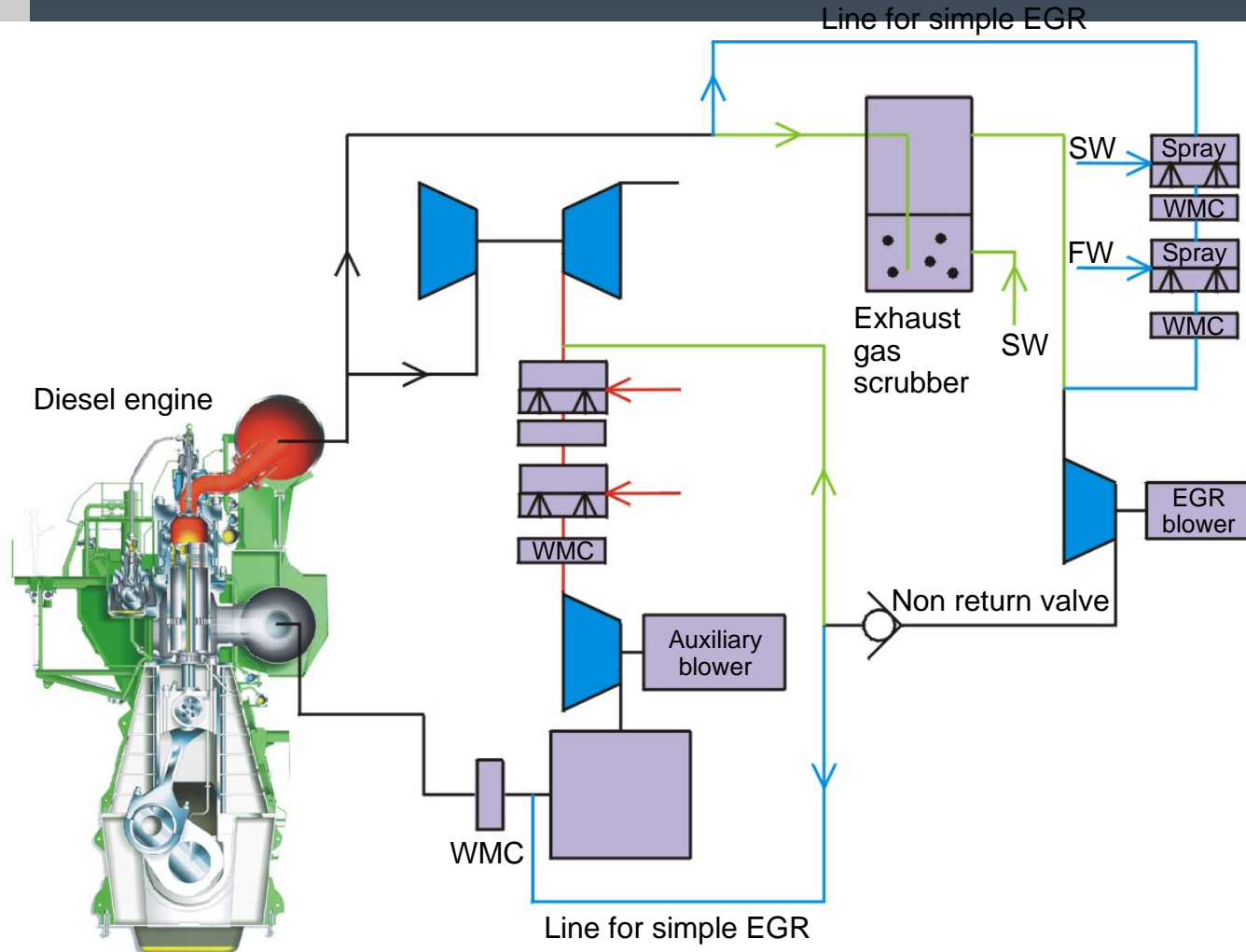

Schematic Design of EGR

Application on 4T50ME-X

L/74160-4.0/0502

(2430/NK)