

# TASK 4.1: Combined Cycle

## Objectives:

- Development of the “Hot Engine” combined cycle concept
- Prototype tests of concept and components

## Progress Highlights:

- Combined cycle concept evaluation, in progress
- Design of suitable engine components, in progress
- Turbocompounded Engine cycle simulations completed
- New generation piston with limited cooling tested
- Cylinder liner development in progress
- New materials resisting hot corrosion/oxidation under testing

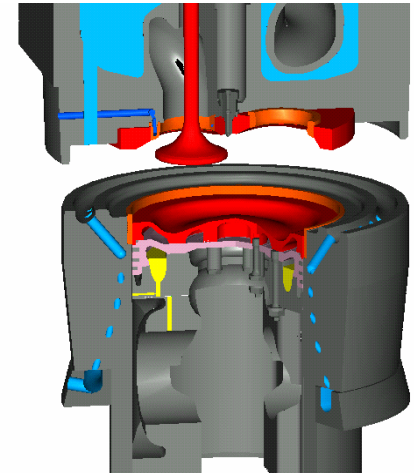

Partners: **ABB**

M. JÜRGENSEN  
FLENSBURG 

**MAHLE**  
PISTONS AND ENGINE COMPONENTS  
FILTER SYSTEMS VALVE TRAIN SYSTEMS

  
**WÄRTSILÄ**