

TASK 3.2: Intelligent turbocharging

Objectives:

- Variable flow area turbocharger components for two and four stroke diesel engines
- Investigation of electrically assisted turbocharger (PTI/PTO) for two stroke diesel engines
- Multistage turbocharging investigations



Progress Highlights:

- Fully automatic variable flow area components applications to 2-stroke engines completed
- Conceptual study of variable compressor area components, in progress
- PTI / PTO test unit manufacturing complete
- Two-stage turbocharging system commissioned on a burner test rig

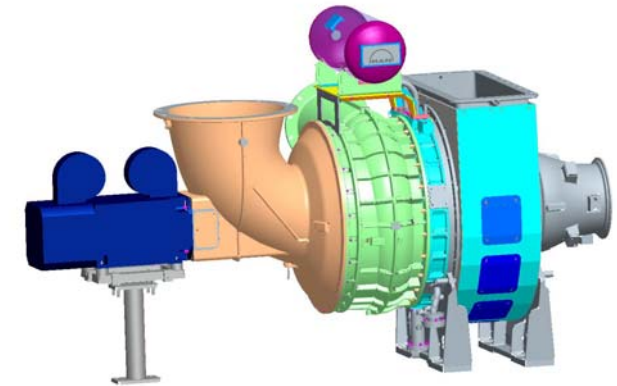

Partners:



I.P. HERCULES

Partners Forum, Copenhagen 5/10/2006